

# TSL-600SD

Floor mounted track

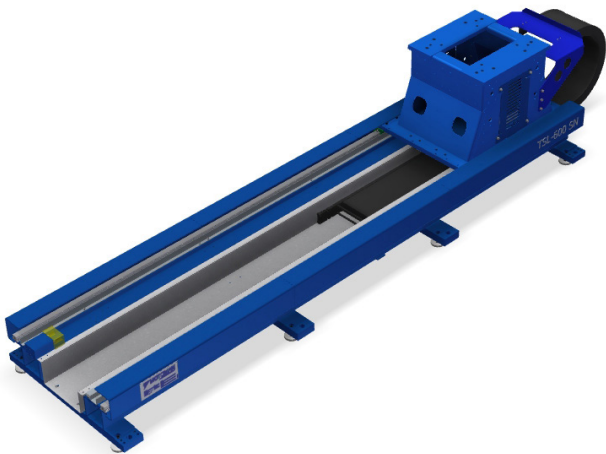

This is a servo powered floor mounted track with one robot carrier. It can be used to increase the robot's working range e.g. when welding large objects. The TSL track is prepared for zeroing function.

The TSL-600 track is only available in two, three or four meters total length.

## Options

- Automatic lubrication (rack and guide blocks)
- Robot stands in different heights
- Bracket for wire barrel

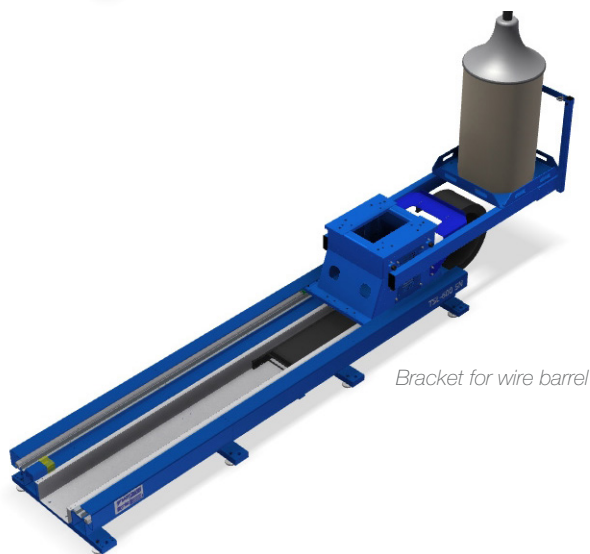

*Bracket for wire barrel*

## Key benefits

- Outstanding speed
- Quiet operation
- Dedicated arc welding track

# TSL-600SD

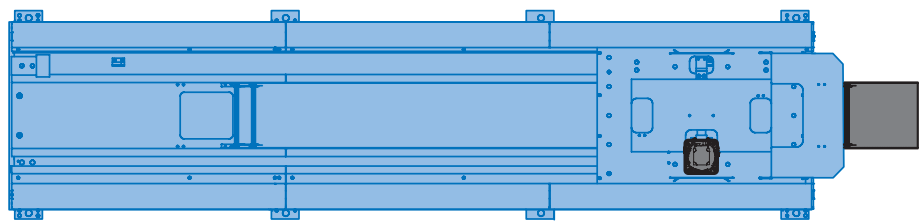
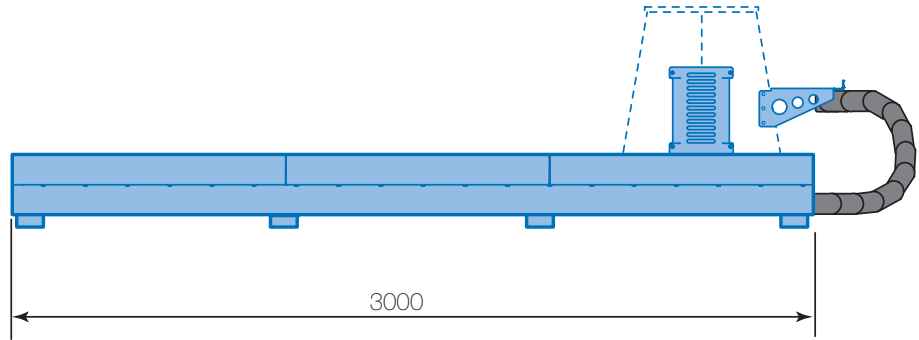
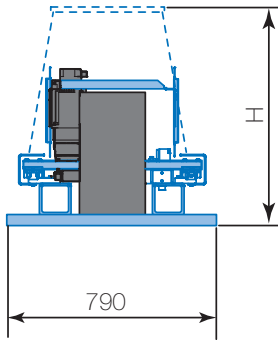

All dimensions are for reference only.

Request detailed drawings for design/engineering requirements!

Technical data		TSL-600SD
Maximum payload		600 kg
Maximum speed		1.8 m/s
ED		50%
Acceleration velocity		3.0 m/s <sup>2</sup>
Travel 500 mm		0.83 sec
Travel 1000 mm		1.16 sec
Repetitive position accuracy		±0.05 mm
Height (H) including robot stand		687, 887, 1087, 1287 or 1487 mm
Standard length (L)		2,3 or 4 meter
Travel length (stroke)		L-850 mm
For robots	DX200	MA1440, MA2010, MH12, MH24
	YRC1000	AR1440, AR2010, GP25-12, GP25

# YASKAWA



YASKAWA Nordic AB  
PO Box 504  
SE-385 25 Torsås, SWEDEN

Phone +46 480 41 78 00  
info.se@yaskawa.eu.com  
www.yaskawa.eu.com